

Pack Mule™ Stick-Built Bottom Dump Trailer



Standard Trailer Specifications*

Dimensions	40' Length x 96" Width x 10'1" Height
Weight	13,200 lbs. (± 3%) with 10" Bang Boards
King Pin/Coupler Ht.	18" / 49"
Color	White, Black or Gray
Sides	10 GA. AR 450 Wear Plate
Lighting	Standard LED Lighting
Capacity	23.5 C.Y. Water Level w/ 10" Bang Boards

Axles	25,000 lb. 5" Tubular , 5/8" Wall
Suspension	50,000 lb. 4-Spring Tandem
Tires/Wheels	11R X 24.5 16 Ply Radials / 10 Hole Hub Piloted Steel
Fenders	Front and Rear Bolt-On (Aluminum)
Paint	High-Gloss, Reverse-Impact, UV-Protectant, Rust-Inhibiting
Upper Hopper	16' x 88" Top Opening
Lower Hopper	54" x 108" Hopper Opening

*Standard features or specifications are subject to change without notice.

Details



Air & Oil Filter

The air filter keeps water out of the lines while the oil filter keeps valves and cylinders lubricated.



Pitch Control Link/Slide Lock Pin

The Pitch Control Link adjustment is used to keep the doors closed. The Slide Lock Pin is designed to lock the doors while traveling, dumping and during repairs.

CONSTRUCTION
TRAILER
SPECIALISTS

Stick-Built Bottom Dump Line Drawing

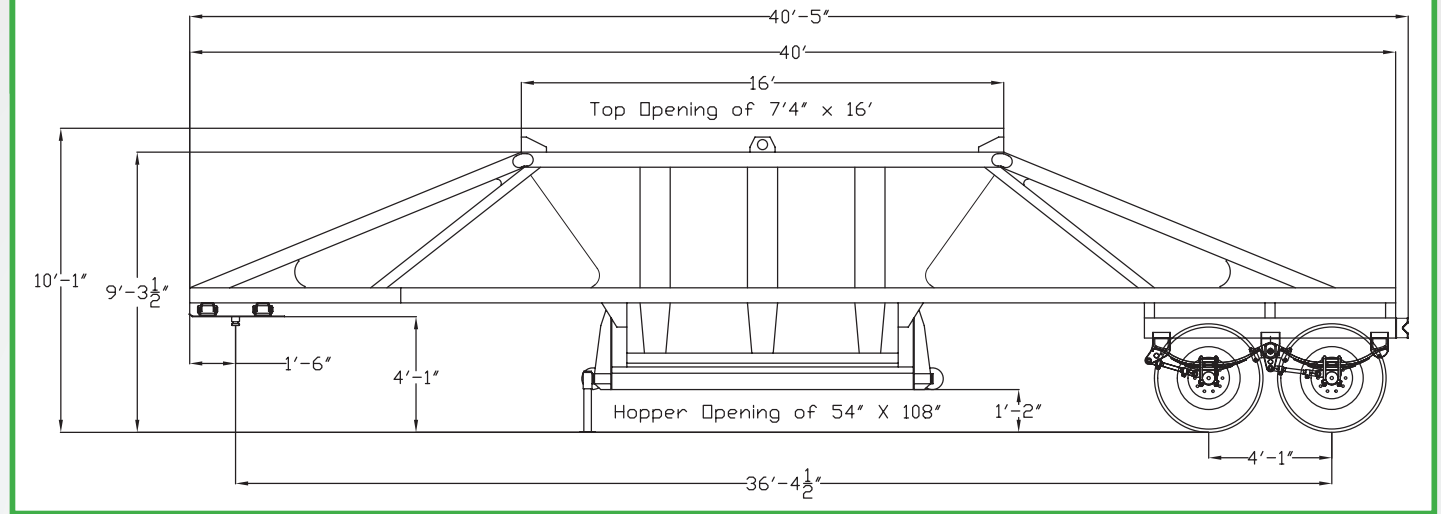

Options

- » 102" Width
- » Air Ride Suspension
- » Scale Systems
- » Parallel Spindles
- » Versa Valve
- » Infinite Gate
- » Lift Axle
- » Custom Colors
- » Numerous Tarps
- » Numerous Tires & Wheels
- » Multiple Pushblock Configurations
- » Additional Options Available Upon Request

For more information, please visit our website at constructiontrailerspecialists.com or call us toll free at 888-669-0003.