

# Quarter Frame Elliptical End Dump Trailer



## Standard Trailer Specifications\*

Dimensions	26' Length x 102" Width x 58" Side Height
Lighting	Standard LED Lighting
King Pin/Coupler Ht.	18" / 49"
Color	White, Black, Gray, Blue or Red
Body	1/4" AR 450
Nose & Gate	3/16" AR 450
Tail Gate	Hi-Lift / Free Flow Combo, 6" Apron

Axles	25,000 lbs. 5" Tubular, 5/8" Wall
Suspension	50,000 lb. Air Ride
Tires/Wheels	11R x 24.5 Radials / 10 Hole Hub Piloted Steel
Paint	High-Gloss, Reverse-Impact, UV-Protectant, Rust-Inhibiting
Draft Arms	Fabricated I-Beam with 2-Speed Landing Gear
Fenders	Rear Aluminum Bolt-On
Capacity	31.5 Cubic Yards

\*Standard features or specifications are subject to change without notice.

## Details



### Spreader Apron

Allows for more even spread of material during dump cycle.



### Double Hinge Tailgate

Allows for hi-lift or free-flow action of tailgate.

**CONSTRUCTION**  
**TRAILER**  
**SPECIALISTS** ©©

## Elliptical End Dump Line Drawing

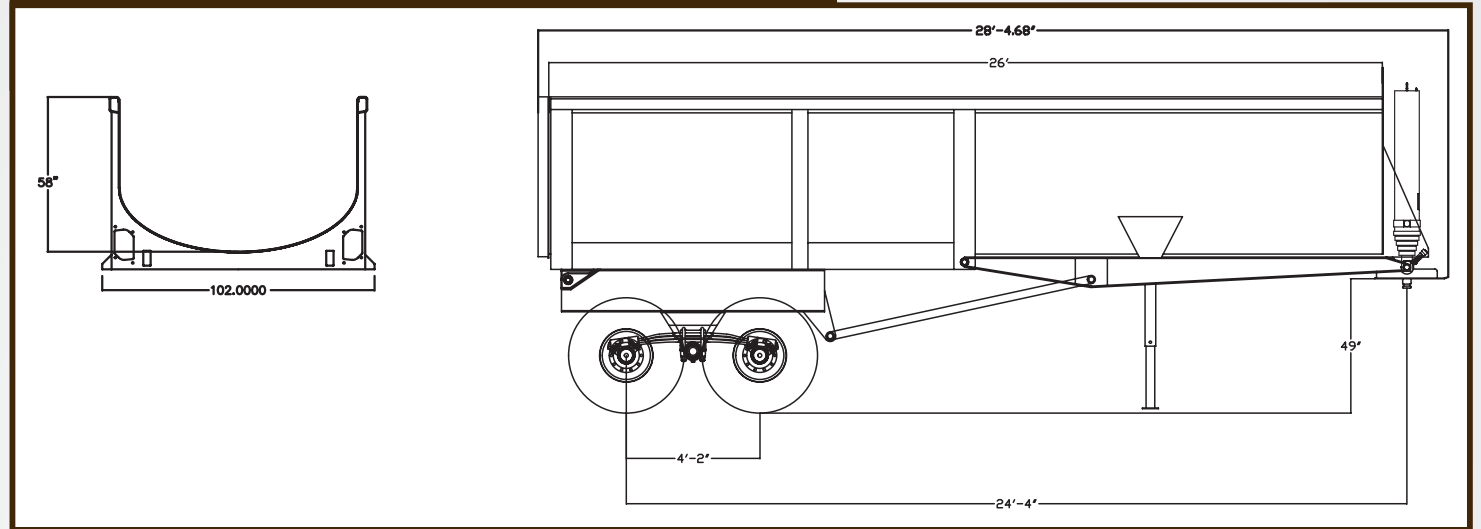

## Options

- » Single Point Suspension
- » Full Frame
- » Front Fenders
- » Numerous Tarp Options
- » Scale and Tire Inflation Systems
- » Custom Lengths and Side Heights
- » Cab Kit
- » Lift Axle
- » Dura-Light Hub and Drum
- » Aluminum Wheels



For more information, please visit our website at [constructiontrailerspecialists.com](http://constructiontrailerspecialists.com) or call us toll free at 888-669-0003.