

BEST TARPS

2025

ROLL MASTER[®]

SYSTEMS



BEST TARPS

REPLACEMENT ROLL TARPS

YELLOW ORANGE

GREEN GRAY

WHITE RED BLUE

BLACK

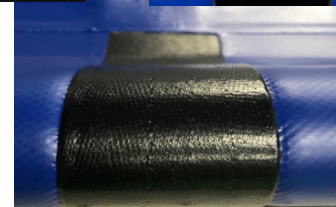
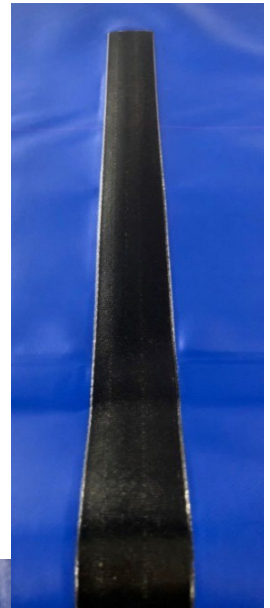

The **BEST** Roll Tarp on the market is the Roll Master threadless roll tarp.

NO THREAD-NO GLUE AND GAURANTEED WELDS.

No thread to rot, & weaken the tarp, & leak through all the needle holes. Best Tarps uses the highest quality vinyl and on standard width roll tarps for 96 OR 102 wide trailers, uses 1 piece material so there are no panels welded together.

This makes for the smoothest rolling – **BEST** quality tarp on the market!

BEST TARPS

REPLACEMENT ROLL TARPS

STANDARD **18 OZ** VINYL

MESH ROLL TARPS W/VINYL REINFORCEMENTS **ADD 25.00** AND THE LETTER M TO END OF PART #

TARP SIZE	123" WIDE FOR 96 WIDE TRAILER PART #	129" WIDE FOR 102 WIDE TRAILER PART #
14 FT	RT14	RT14W
15 FT	RT15	RT15W
16 FT	RT16	RT16W
17 FT	RT17	RT17W
18 FT	RT18	RT18W
19 FT	RT19	RT19W
20 FT	RT20	RT20W
21 FT	RT21	RT21W
22 FT	RT22	RT22W
23 FT	RT23	RT23W
24 FT	RT24	RT24W
25 FT	RT25	RT25W
26 FT	RT26	RT26W
27 FT	RT27	RT27W
28 FT	RT28	RT28W
29 FT	RT29	RT29W
30 FT	RT30	RT30W
31 FT	RT31	RT31W
32 FT	RT32	RT32W
33 FT	RT33	RT33W
34 FT	RT34	RT34W
35 FT	RT35	RT35W
36 FT	RT36	RT36W
37 FT	RT37	RT37W
38 FT	RT38	RT38W
39 FT	RT39	RT39W
40 FT	RT40	RT40W
41 FT	RT41	RT41W
42 FT	RT42	RT42W
43 FT	RT43	RT43W
44 FT	RT44	RT44W
45 FT	RT45	RT45W
46 FT	RT46	RT46W
47 FT	RT47	RT47W
48 FT	RT48	RT48W



YOU HAVE HAD A MANUAL ROLL SYSTEM.....IT IS **TIME TO EVOLVE**

The **Roll Master Evolution Electric System** features our powerful Roll Master HD motor attached to our gear reduction system, insuring your tarp is tight and secure at all times with the exact torque needed for load protection and containment. This powerful system is designed to walk over heaped loads with ease.

The Evolution offers heavy duty aluminum arms backed by a lifetime warranty against breaking.

The Evolution can be fitted to most trailers in the industry. This system can be used to convert your manual crank system to one that opens and closes your tarp by the simple push of a button from the comfort of your truck, or by the optional remote control.



Part # **EVOLUTION-DA**
Part # **EVOLUTION-SA**
Part # **EVOLUTION-DAH**

EVOLUTION DUAL ARM CONVERSION SYSTEM
EVOLUTION SINGLE ARM CONVERSION SYSTEM
EVOLUTION DUAL ARM HINGED CONVERSION

EVOLUTION PARTS

PART # **EVTMA-R** COMPLETE REAR TRAILER MOUNT

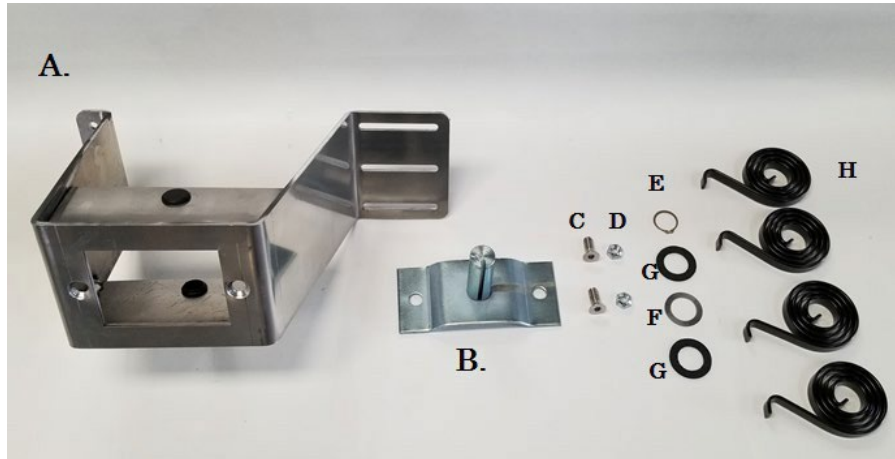

- A. EV-LATMS EVOLUTION LOWER ARM TRAILER MOUNT STAND
- B. FTB-SMB4 FTB/EVOLUTION STEEL 4 SPRING MOUNTING BRACKET
- C. HDW-5 HARDWARE- 1/2" X 1-1/4" STAINLESS FLAT HEAD HEX DRIVE SCREW
- D. HDW-12 HARDWARE- 1/2" STAINLESS NYLON INSERT LOCKNUT
- E. FTB-SR FTB/EVOLUTION SNAP RING
- F. FTB-SPW FTB/EVOLUTION STEEL PIVOT WASHER
- G. EV-LAW1 EVOLUTION LOWER ARM ABS 1/8" WASHER
- H. FTB-S FTB/EVOLUTION SPRING

PART# **EVLAA-R** LOWER REAR ARM ASSEMBLY

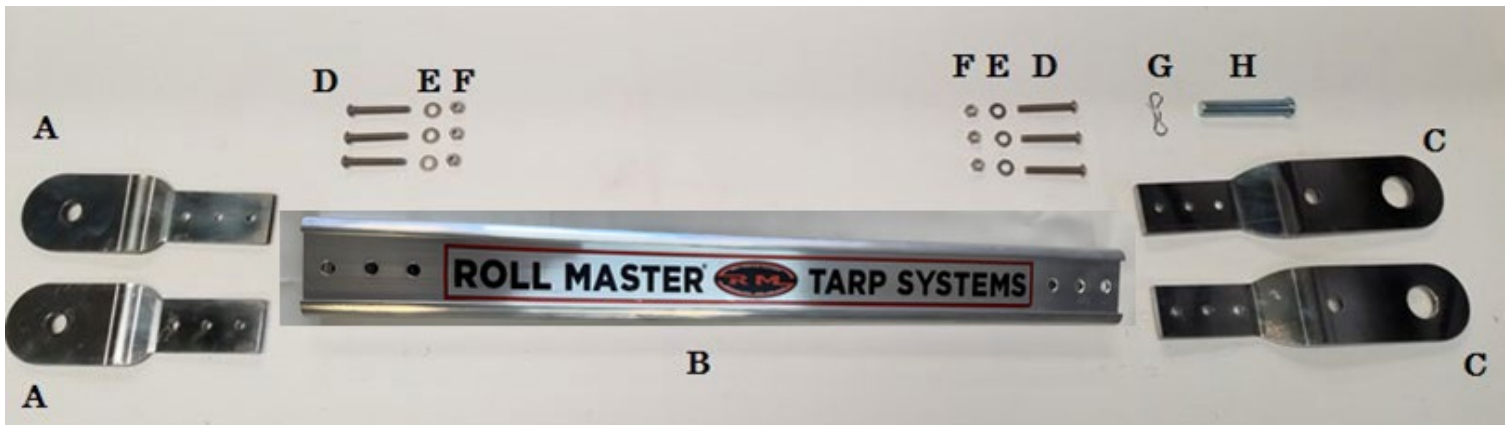

- A. EV-LAPP EVOLUTION LOWER ARM PIVOT PLATE
- B. EV-LA EVOLUTION LOWER ARM
- C. EV-LASP24 EVOLUTION LOWER ARM 4-SPRING PLATE
- D. HDW-2 HARDWARE- 5/16 X 2-1/4" STAINLESS BUTTON HEAD HEX DRIVE SCREWS
- E. HDW-14 HARDWARE- 5/16 STAINLESS WASHER
- F. HDW-10 HARDWARE- 5/16 STAINLESS NYLON INSERT LOCKNUT
- G. PIN-BT BOW TIE PIN CLIP EV-P
- H. IN4 EVOLUTION- 5/8 X 3-1/2 CLEVIS PIN

EVOLUTION PARTS

PART # **EVTMA-F** COMPLETE FRONT TRAILER MOUNT

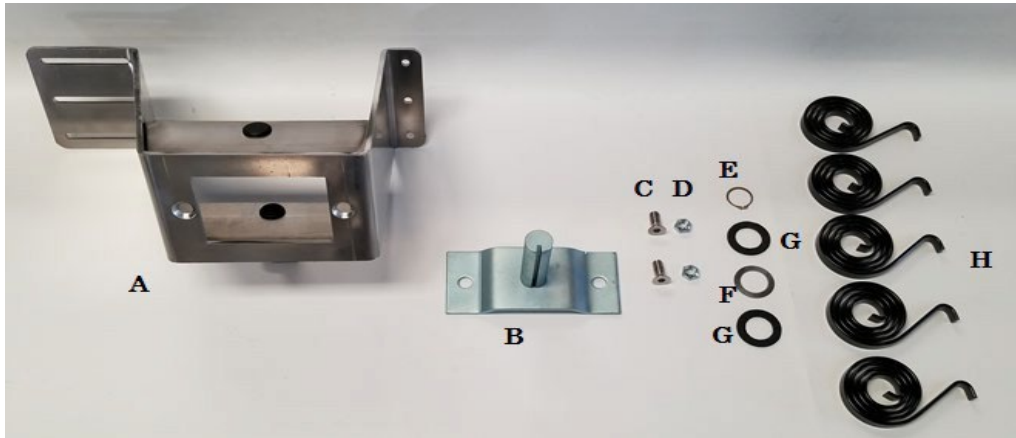

- A. EV-LATMS EVOLUTION LOWER ARM TRAILER MOUNT STAND
- B. FTB-SMB5 FTB/EVOLUTION STEEL 5 SPRING MOUNTING BRACKET
- C. HDW-5 HARDWARE- 1/2" X 1-1/4" STAINLESS FLAT HEAD HEX DRIVE SCREW
- D. HDW-12 HARDWARE- 1/2" STAINLESS NYLON INSERT LOCKNUT
- E. FTB-SR FTB/EVOLUTION SNAP RING
- F. FTB-SPW FTB/EVOLUTION STEEL PIVOT WASHER
- G. EV-LAW1 EVOLUTION LOWER ARM ABS 1/8" WASHER
- H. FTBS EVOLUTION LOWER ARM ABS 1/8" WASHER
- I. FTBS FTB/EVOLUTION SPRING

PART # **EVLAA-F** LOWER FRONT ARM ASSEMBLY



- A. EV-LASP25 EVOLUTION LOWER ARM 5-SPRING PLATE
- B. EV-LA EVOLUTION LOWER ARM
- C. EV-LAPP EVOLUTION LOWER ARM PIVOT PLATE
- D. HDW-2 HARDWARE- 5/16 X 2-1/4" STAINLESS BUTTON HEAD HEX DRIVE SCREWS
- E. HDW-14 HARDWARE- 5/16 STAINLESS WASHER
- F. HDW-10 HARDWARE- 5/16 STAINLESS NYLON INSERT LOCKNUT
- G. PIN-BT BOW TIE PIN CLIP
- H. EV-PIN5 EVOLUTION- 5/8 X 4 CLEVIS PIN

PART # EVUAA-R

UPPER REAR ARM ASSEMBLY

- A. EV-UAPR UPPER ARM PLATE REAR
- B. EV-UAR UPPER ARM REAR
- C. EV-UAWP UPPER ARM ABS WEAR PLATE
- D. EV-UABP UPPER ARM BACKING PLATE
- E. EV-UAB UPPER ARM BEARING
- F. ****
- G. ****
- H. EV-SR EVOLUTION SNAP RING $\frac{3}{4}$ "
- I. EV-UAW2 UPPER ARM STAINLESS WASHER
- J. EV-PP EVOLUTION PIVOT PIN
- K. HDW-11 $\frac{3}{8}$ STAINLESS NYLON INSERT LOCKNUT
- L. HDW-6 $\frac{3}{8}$ X 1-1/2" STAINLESS SOCKET HEAD SCREW
- M. HDW-2 $\frac{5}{16}$ X 2-1/4" BUTTON HEAD HEX SCREW
- N. HDW-14 $\frac{5}{16}$ STAINLESS WASHER
- O. HDW-10 $\frac{5}{16}$ STAINLESS NYLON INSERT LOCKNUT

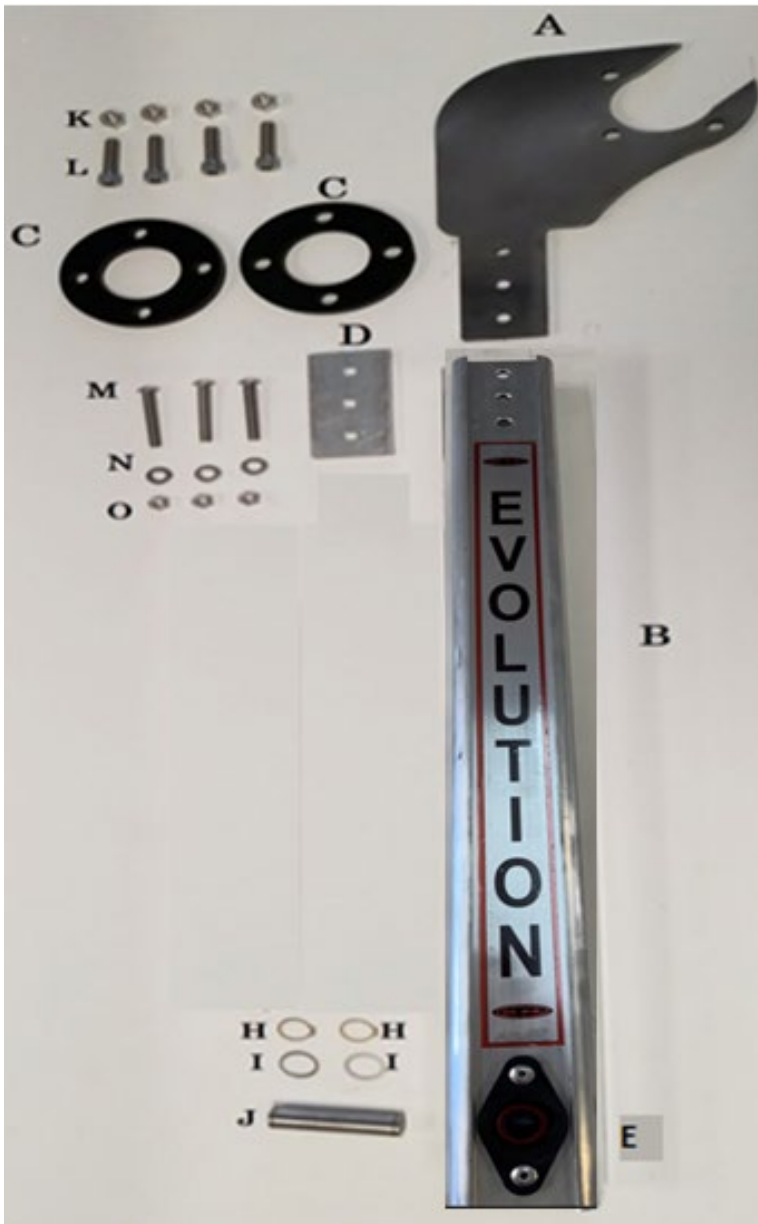

PART # EVUAA-F

UPPER FRONT ARM ASSEMBLY

- A. EV-UAMP UPPER ARM MOTOR PLATE
- B. EV-UAF UPPER ARM FRONT
- C. EV-WTB WIRE TERMINAL BLOCK
- D. EV-UABP UPPER ARM BACKING PLATE
- E. EV-S GAS STRUT
- F. EV-SBU STRUT BRACKET UPPER
- G. EV-SBL STRUT BRACKET LOWER
- H. EV-SR EVOLUTION SNAP RING $\frac{3}{4}$ "
- I. EV-UAW2 UPPER ARM STAINLESS WASHER
- J. EV-PP EVOLUTION PIVOT PIN
- K. HDW-9 10-32 X 1" STAINLESS SOCKET HEAD SCREW
- L. HDW-3 $\frac{5}{16}$ X 2-1/2" BUTTON HEAD HEX SCREW
- M. HDW-1 $\frac{5}{16}$ X 2-3/4" MOTOR COVER SCREW
- N. HDW-14 $\frac{5}{16}$ STAINLESS WASHER
- O. HDW-10 $\frac{5}{16}$ STAINLESS NYLON INSERT LOCKNUT
- P. HDW-16 10-24 STAINLESS SELF TAPPING SCREW
- Q. HDW-14 $\frac{5}{16}$ STAINLESS WASHERS
- R. EV-EC EVOLUTION $\frac{5}{16}$ E-CLIP
- S. EV-SBP STRUT BRACKET PIN $\frac{5}{16}$ X 1"
- T. EV-UAB UPPER ARM FLANGE BEARING

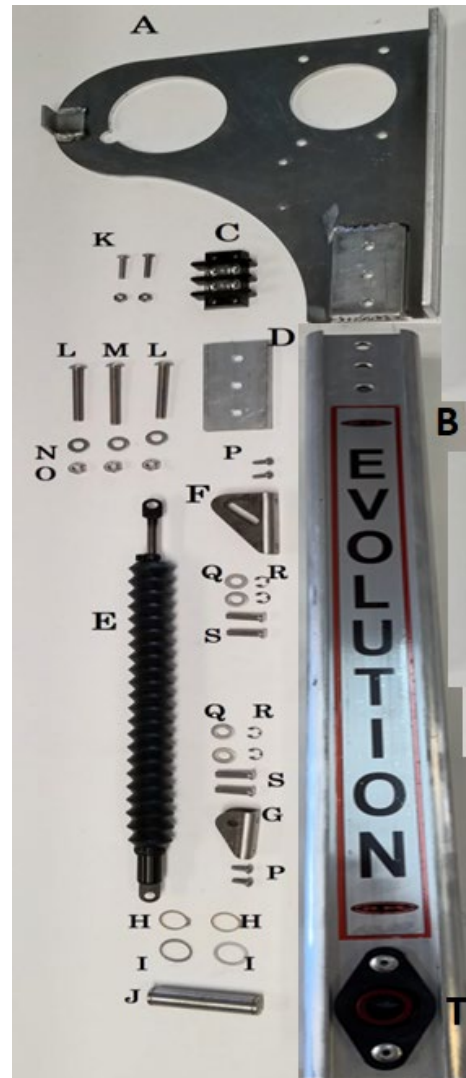

EVOLUTION HINGED REAR ARM ASSEMBLY Part # EV-HAAC
COMPLETE ASSEMBLY (TOP AND BOTTOM) PIC 1 AND 2

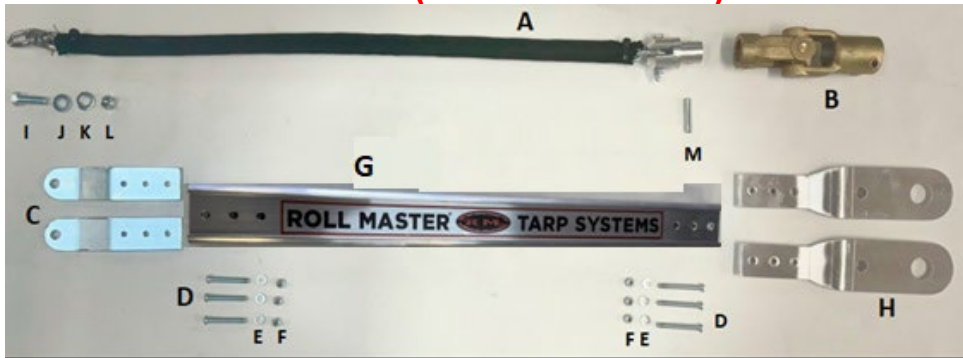

PIC 1

PIC 1: EVOLUTION HINGED LOWER REAR ARM -UNASSEMBLED

- A. EV-LAPP EVOLUTION HINGED ARM CHAIN ASSEMBLY
- B. EV-UJ EVOLUTION U-JOINT FOR HINGED ARM
- C. EV-HAP EVOLUTION HINGED ARM PLATE
- D. HDW-2 HARDWARE- 5/16 X 2-1/4" STAINLESS BH HEX DRIVE SCREW
- E. HDW-14 HARDWARE- 5/16 STAINLESS WASHER
- F. HDW-10 HARDWARE- 5/16 STAINLESS NYLON INSERT LOCKNUT
- G. EV-LA EVOLUTION LOWER ARM
- H. EV-LAPP EVOLUTION LOWER ARM PIVOT PLATE
- I. HDW-23 1/2" X 2" BOLT
- M. EV-PP Evolution Pivot Pin

PART # EVTMA-R COMPLETE REAR TRAILER MOUNT

- A. EV-LATMS LOWER ARM TRAILER MOUNT STAND
- B. FTB-SMB4 EVOLUTION STEEL 4 SPRING MOUNTING BRACKET
- C. HDW-5 1/2" X 1-1/4" FLAT HEAD HEX DRIVE SCREW
- D. HDW-12 1/2" STAINLESS NYLON INSERT LOCKNUT
- E. FTB-SR EVOLUTION SNAP RING
- F. FTB-SPW EVOLUTION STEEL PIVOT WASHER
- G. EV-LAW1 EVOLUTION LOWER ARM ABS 1/8" WASHER
- H. FTB-S FTB/EVOLUTION SPRING

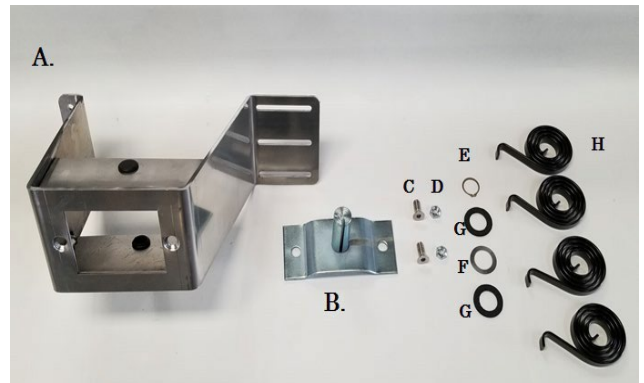

PIC 2

EV-HAA PIC3 HINGED ARM ASSEMBLED



PART # EV-MMA MOTOR MOUNT ASSEMBLY COMPLETE

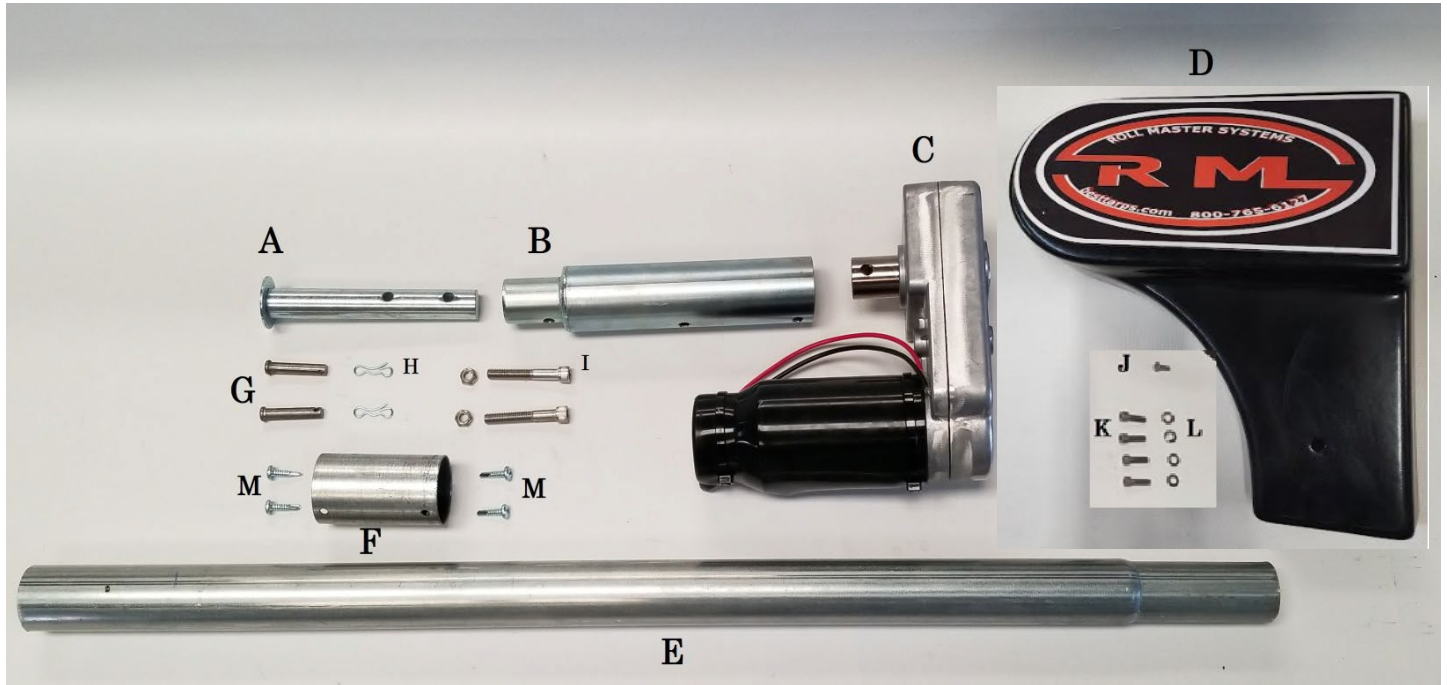

- | | | | |
|-----------|------------------------|-----------|-----------------------------|
| A. EV-MS | MOTOR SHAFT 1" X 7" | G. EV-MCP | MOTOR CLEVIS PIN |
| B. EV-MSC | MOTOR SHAFT CONNECTOR | H. PIN-BT | BOW TIE CLIP |
| C. EV-M | EVOLUTION MOTOR | I. HDW-7 | 3/8 X 2-1/2 SOCKET HD SCREW |
| D. EV-MC | EVOLUTION MOTOR COVER | J. HDW-16 | 10-24 SELF TAP SCREW |
| E. EV-RTE | ROLL TUBE EXTENDER 36" | K. HDW-8 | 1/4 X 3/4 SOCKET HEAD SCREW |
| F. EV-PS | PIPE SLEEVE | L. HDW-13 | 1/4 SPLIT LOCK WASHER |
| | | M. UC02 | 3/4 SELF TAPPING SCREW |



- | | | |
|---|-----------|----------------------|
| A | FTBW6-40 | 6 GA WIRE 40' SPOOL |
| B | FTBW14-12 | 14 GA WIRE 12' SPOOL |
| C | EV-WL1 | 3/4 WIRE LOOM 6' |
| D | EV-WL2 | SMALL WIRE LOOM 1' |
| E | FTBW6 | 6 GA WIRE PER FT |



- | | | |
|---|-----------|----------------------------|
| | RETURN-R | ECONO REAR RETURN COMPLETE |
| A | RETURN-EC | REAR COLLAR |
| B | RETURN-EG | REAR GUIDE |
| C | RETURN-ER | 1/2" X 12' RETURN CORD |
| D | BOLT-ST | 3/8 SELF TAP BOLTS |

**PART EV-ARR
ARM RETAINING
RING**





ROLL MASTER EVOLUTION SYSTEMS ELECTRIC REPLACEMENT PARTS

EV-MC MOTOR COVER



**EV-MO EVOLUTION
MOTOR ONLY**



**EV-M EVOLUTION
MOTOR & COVER**



**FTB-EB
50-AMP BREAKER**

**EV-RB REMOTE BOX
WITH KEY FOB**



**FTB-ES
SOLENOID**



**FTB-ESK1
ROCKER SWITCH KIT**

**EV-WTB
WIRE TERMINAL BLOCK**



**FTB-ETPS
Trailer Plug Set**

TIME TO EVOLVE THE OLD STYLE RETURN ROPE ASSEMBLY!

EVOLUTION FRONT ARM ASSIST

Replace your old front return rope assembly with the NEW Evolution front arm assist.
The powerful spring tension makes hand cranking your manual roll system a breeze
and no more broken ropes! PART NUMBER EV-FAA



EV-ARR
ARM RETAINING RING

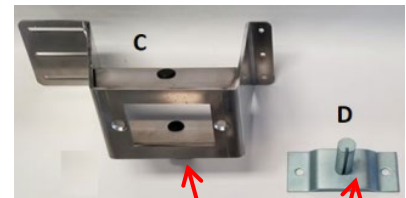
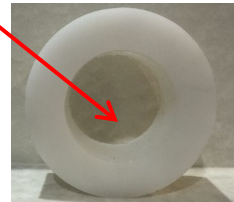

PART NUMBER: EV-FAA
COMPLETE FRONT ARM ASSIST

REPLACEMENT PARTS FOR FRONT ARM ASSIST

- A) EV-FAA-LA Evolution front arm assist lower arm
- B) EV-FAA-UA Evolution front arm assist upper arm
- C) EV-LATMS Evolution Trailer Mount Stand
- D) FTB-SMB4 Steel Mounting Bracket 4 Spring
- E) FTB-SR Snap Ring
- F) FTB-SPW Steel Pivot Washer
- G) FTBS Spring





THE ROLLMASTER SYSTEM COMES STANDARD WITH 18oz TARP, ALUMINUM SQUARE FRONT & REAR CAPS, STANDARD TARP STOPS, SPLINED CRANK ASSEMBLY, FRONT RETURN ASSEMBLY. UPGRADES/OPTIONS LISTED BELOW

FOR OPEN TOP VANS & SEMI GRAIN TRAILERS

RMSS30 OR RMSS32 COMPLETE ROLL MASTER SYTEM 30-32 FT TRAILER

RMSS34 OR RMSS36 COMPLETE ROLL MASTER SYSTEM 34-36 FT TRAILER

RMSS38 OR RMSS40 COMPLETE ROLL MASTER SYSTEM 38-40 FT TRAILER

RMSS42 OR RMSS44 COMPLETE ROLL MASTER SYSTEM 42-44 FT TRAILER

RMSS46 OR RMSS48 COMPLETE ROLL MASTER SYSTEM 46-48 FT TRAILER

RMSS50 OR RMSS52 COMPLETE ROLL MASTER SYSTEM 50-52 FT TRAILER

OPTIONS AND UPGRADES:

22 OZ VINYL TARP

1" GALVANIZED BOWS

1-1/4" GALVANIZED BOWS

UNBREAKABOWS W/HOLDERS

EZ OFF TARP STOPS

RADIUS FRONT CAP

UNIVERSAL FRONT CAP

LONG CRANK ARM W/96" EXTENSION

BREAKAWAY CRANK ASSEMBLY

RIDGE STRAP ASSEMBLIES

ROLL TUBE DEFLECTORS –plastic and metal



MAKE IT ELECTRIC!!!!

EVOLUTION DUAL ARM CONVERSION EVOLUTION

SINGLE ARM CONVERSION EVOLUTION DUAL HINGED

ARM CONVERSION

REMOTE BOX WITH KEY FOB



THE ROLL MASTER END DUMP TARP SYSTEMS COME STANDARD WITH 22 OZ VINYL, OFFSET EZ OFF TARP STOPS, BREAKAWAY CRANK ASSEMBLY, STEEL 1-1/4 GALVANIZED BOWS

- RMSD22 COMPLETE SYSTEM FOR 22' BED**
- RMSD24 COMPLETE SYSTEM FOR 24' BED**
- RMSD26 COMPLETE SYSTEM FOR 26' BED**
- RMSD28 COMPLETE SYSTEM FOR 28' BED**
- RMSD30 COMPLETE SYSTEM FOR 30' BED**
- RMSD32 COMPLETE SYSTEM FOR 32' BED**
- RMSD34 COMPLETE SYSTEM FOR 34' BED**
- RMSD36 COMPLETE SYSTEM FOR 36' BED**
- RMSD38 COMPLETE SYSTEM FOR 38' BED**
- RMSD40 COMPLETE SYSTEM FOR 40' BED**
- RMSD42 COMPLETE SYSTEM FOR 42' BED**

OPTIONS AND UPGRADES:

- Nylabows w/holders**
- Universal aluminum front cap**
- 80" extension breakaway crank assembly**
- 96" extension breakaway crank assembly**
- Spring locking crank retainers**
- Roll tube deflectors-plastic**
- Roll tube deflectors-metal**

ASK ABOUT MAKING IT ELECTRIC!





ROLL MASTER

SYSTEMS

FOR FARM BEDS

RMF10-12 ROLL MASTER SYSTEM 10-12 FT
RMF14-16 ROLL MASTER SYSTEM 14-16 FT
RMF18-20 ROLL MASTER SYSTEM 18-20 FT
RMF22-24 ROLL MASTER SYSTEM 22-24 FT

ROLL MASTER CART SERIES SYSTEMS



ROLL MASTER NO END CAP SERIES				
		WIDTH		
L	SZ	8	9	10
E	10-12	CALL FOR PRICING		
N				
G	14-16			
T				
H		ANY SIZE LARGER NEEDS END CAPS		

WITH FABRIC END CAPS						
ROLL MASTER SERIES WITH END CAPS						
		WIDTH				
L	SZ	8	9	10	11	12
E	10-12	CALL FOR PRICING				
N	14-16					
G						
T	18-20					
H						



ALL ROLLMASTER SYSTEM™ ALUMINUM END CAPS ARE MADE WITH .100 ALUMINUM INSTEAD OF INDUSTRY STANDARD .80

ALUMINUM END CAPS

1.CAPA96F	ALUMINUM END CAP 96" SQUARE FRONT
2.CAPA96B	ALUMINUM END CAP 96" SQUARE BACK
3.CAPA102F	ALUMINUM END CAP 102" SQUARE FRONT
4.CAPA102B	ALUMINUM END CAP 102" SQUARE BACK
5.CAPA96R	ALUMINUM END CAP 96" FRONT RADIUS

PART #	DESCRIPTION
6.CAPA-R102	ALUMINUM END CAP 102" FRONT RADIUS
7. CAP96U	ALUMINUM END CAP 96" UNIVERSAL
8. CAP102U	ALUMINUM END CAP 102" UNIVERSAL
9.TRIM	TRIM SEAL-PER FOOT



FABRIC CAPS- all fabric caps made with 28 and 40 oz vinyl

PART #	DESCRIPTION
CAPF-C02	Complete Fabric Square front 96" or 102"
CAPF-C01	Complete Fabric Radius front 96" or 102"
CAPF-C03	Complete Fabric REAR CAP 96" or 102"
CAPF03	FABRIC Cap only 96" or 102" REAR
CAPF02	FABRICE Cap only Square Front 96" or 102"
CAPF01	FABRIC Cap only Radius Front 96" or 102"
ALUM12	Aluminum Flat Bar 1"x 144"

TARP TUBES AND ACCESSORIES



ITEM	PART #	DESCRIPTION
1.	PIPE02	2"X 20' ROLL TUBE
2.	PIPE04	2"X 24' ROLL TUBE
3.	PIPE05	2" X 20' ROLL TUBE W/SPLINE
4.	PIPE06	2" X 24' ROLL TUBE W/SPLINE
5.	PIPER01	2" X 20' ROLL TUBE W/SQ END
6.	PIPER02	2" X 24' ROLL TUBE W/SQ END
7.	PIPE01	1 1/8" X 20' FIXED TUBE
8.	PIPE03	1 1/8" X 24' FIXED TUBE
9.	CONN01	1 1/8" PIPE CONNECTOR
10.	CONN02	2" PIPE CONNECTOR
11.	SPLINE	SPLINE SHAFT
12.	SPLINE02	SPLINE SHAFT W/CONNECTOR
13.	UC01	U-CLAMP
14.	UC02	U-CLAMP SCREWS 3/4"
15.	UC02-L	U-CLAMP SCREWS 1"
16.	SQ COG	SQUARE COG
17.	SPLINE03	SLIP SPLINE SHAFT
18.	PIPE-S	2-1/2" X 30" PIPE STIFFNER

ROLL TUBE DEFLECTORS

PROTECT THE SIDE OF YOUR TRAILER

1. PIPE-D BLACK PLASTIC ROLL TUBE DEFLECTOR
2. PIPE-DM METAL ROLL TUBE DEFLECTOR



WIND GUST STRAP

The wind gust strap helps protect your tarp and pipes from being damaged in strong winds

PART NUMBER: WGS Wind gust strap



RETURN ROPE ASSEMBLIES

ITEM	PART #	DESCRIPTION
1.	RETURN02	COMPLETE FRONT ROLL RETURN ASSEMBLY
2.	RETURN01	RETURN ROPE 3/8 X 12 FOOT LONG
3.	RETURN03	RETURN END PLUG-NLYON
4.	RETURN04	RETURN EYE BOLT
5.	RETURN05	RETURN ROPE-BULK 300 FT SPOOL
6.	RETURN06	PVC TUBE – 10 FT LONG
7.	RETURN RD	REAR CABLE RETURN ASSEMBLY DELUXE
8.	RETURNNRDC	REAR CABLE REPLACEMENT
9.	RETURN02-B	ROPE, PLUG AND EYEBOLT

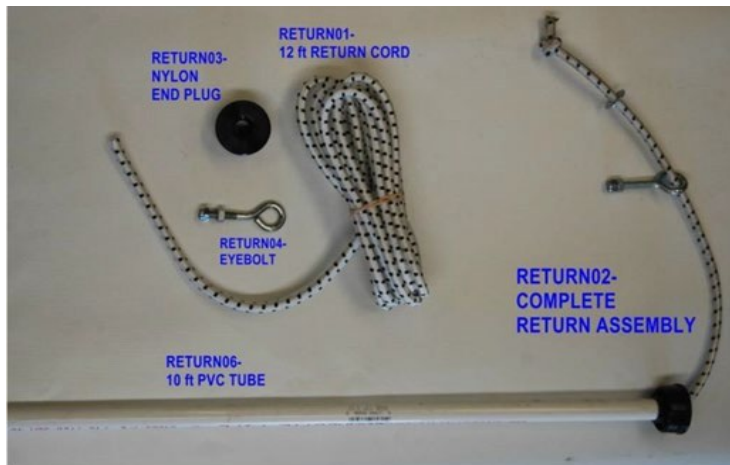

ROLL MASTER LOCKING APPLICATIONS- ALUMINUM LOK- RAIL & RATCHETS & STRAPS



ALUMINUM SIDE MOUNT LOK-RAIL

- LR1** **1 FT SECTION OF LOK-RAIL**
- LR8** **8 FT SECTION OF LOK-RAIL**
- LR24** **24 FT SECTION OF LOK-RAIL**

RATCHET & STRAP ASSEMBLIES

- RTSA-5** **5FT HOLD DOWN**
ASSEMBLY
 - RTSA-7** **7FT HOLD DOWN**
ASSEMBLY
 - RTSA-9** **9FT HOLD DOWN**
ASSEMBLY
 - RTS-S5** **5'RTS STRAP W/D-RING**
 - RTS-S7** **7'RTS STRAP W/D-RING**
 - RTS-S9** **9'RTS STRAP W/D-RING**
-
- RAT02-** **2" RTS RATCHET ONLY**
 - RAT04-** **2" RTS RATCHET WITH WEB & HOOK**



RAT02

TARP STOPS



STOPSWA



STOPRC



stop-oc

STOPOC



STOP01



STOP03



STOP-R

TARP STOPS

ITEM	PART #	DESCRIPTION
1.	STOP01	STANDARD TARP STOP
2.	STOP03	TOP MOUNT TARP STOP
3.	STOPSWA	STANDARD EZ OFF STOP W/ 3" ALUM UPRITE
4.	STOPOC	OFFSET EZ STOP W/6"OFFSET ALUM UPRITE
5.	STOPRC	STANDARD EZ OFF STOP W/RUBBER 3" UPRITE

INDIVIDUAL STOP PARTS

7.	STOPAU	STANDARD 3" ALUMINUM UPRITE
8.	STOPOAU	6" OFFSET ALUMINUM UPRITE
9.	STOPR	3" RUBBER UPRITE
10.	STOPBS	EZ OFF STEEL MOUNT BRACKET
11.	PIN06	CLEVIS PIN ONLY
12.	PIN08	CLEVIS PIN RING ONLY FOR CLEVIS PIN
13.	PIN-BT	BOW TIE PIN ONLY FOR CLEVIS PIN
14.	BOLT-ST	3/8 SELF TAPPING BOLT
15.	PIN-CBT	2 CLEVIS PINS WITH 2 BOW TIES



CRANK02- STANDARD CRANK ARM 28"
CRANK03- LONG CRANK ARM 50"

CRANK06 NYLON CRANK GRIP
CRANK21 BOLT NUT AND WASHER
CRANK06-WB CRANK GRIP W/BOLT



CRANK ASSEMBLIES

1. CRANK01 Standard splined crank assembly w/80" extension
2. CRANK01-B Spline crank assembly w/80" ext & 50" long arm
3. CRANK01-96 Spline crank assembly w/96" ext & standard arm
4. CRANK01-B96 Spline crank assembly w/96" ext & 50" long arm

REPLACEMENT PARTS :

5. CRANK02 Standard crank arm 28"
6. CRANK03 Long crank arm 50"
7. CRANK80 80" crank extension
8. CRANK96 96" crank extension
9. UJ02 Splined u-joint
10. PIN-01 Snapper pin
11. PIN-04 Nylon pin keeper
12. CRANK06 Nylon grip
13. CRANK21 Bolt/nut/washer for crank grip
14. CRANK06-WB Nylong grip with hardware (crank21)

Break-away Crank Assemblies

1. CRANK18 Breakaway crank assembly w/40" extension & retainers
2. CRANK18-NR Breakaway crank assembly w/40" extension-**NO retainers**
3. CRANK18-54 Breakaway crank assembly w/54" extension & retainers
4. CRANK1854-NR Breakaway crank assembly w/54" extension-**NO retainers**
5. CRANK18-80 Breakaway crank assembly w/80" extension & retainers
6. CRANK1880-NR Breakaway crank assembly w/80" extension-**NO retainers**
7. CRANK18-96 Breakaway crank assembly w/96" extension & retainers
8. CRANK1896-NR Breakaway crank assembly w/96" extension -**NO retainers**

REPLACEMENT PARTS:

9. CRANK20 20" Crank Extension
10. CRANK40 40" Crank Extension
11. CRANK54 54" Crank Extension
12. CRANK80-B 80" Crank Extension for breakaway
13. CRANK96-B 96" Crank Extension for breakaway
14. CRANK15 Male knuckle
15. CRANK16 Female knuckle
16. CRANK17 Slide locking tube
17. PIN05-B $\frac{1}{4}$ X 1-1/2" Pin
18. PIN07 $\frac{1}{4}$ X 1-1/4" Pin

RTS RATCHET STRAP CRANK ASSEMBLY

1. CRANK04 RTS COMPLETE CRANK ASSEMBLY W/RETAINERS 6'6" TO BEND
2. CRANK12 RTS COMPLETE CRANK ASSEMBLY-NO RETAINERS 6'6 TO BEND

FOR EXTENDED LENGTH -2 FT LONGER ADD EXT TO PART NUMBER AND ADD

3. CRANK05 RTS CRANK ARM ONLY 6'6" TO BEND
4. CRANK05-EXT RTS CRANK ARM EXTENDED 2 FT
5. UJ03 RTS U-JOINT
6. CRANK14 $\frac{3}{4}$ SQUARE KEY

CRANK HANDLE RETAINERS



RETAIN01-SINGLE RETAINER HOOK



**PIN01-SNAPPER
PIN**

PIN04- NYLON PIN CABLE KEEPER

PIN04-M METAL PIN CABLE KEEPER

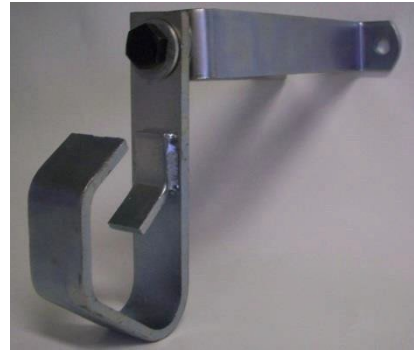

**RETAIN02-COMPLETE
SWIVEL PINLESS RETAINER**



**RETAIN03-SPRING-LOK
RETAINER COMPLETE**



**RETAIN-06
PINLESS HOOK**



**RETAIN-07
7" STAND**



RETAIN04-SPRING LOK CONVERSION KIT



**RETAIN-C
CLEVIS & COTTER**



RETAIN-SL SPRING LOK



**RETAIN-B
BASE PLATE**



**RETAIN-S
RETAINER SPRING**



**RETAIN-W
1/4" FLAT WASHER**



**BOLT-ST
3/8 SELF TAPPING**



CRANK RETAINERS

1. RETAIN01	SINGLE RETAINER
2. PIN01	SNAPPER PIN
3. PIN04	NYLON CABLE FOR SNAPPER PIN
4. RETAIN02	SWIVEL PINLESS CRANK RETAINER
5. RETAIN07	7" RETAINER STAND ONLY
6. RETAIN06	PINLESS RETAINER HOOK ONLY
7. RETAIN03	COMPLETE SPRING-LOK RETAINER
8. RETAIN04	SPRING-LOK CONVERSION

REPLACEMENT PARTS FOR SPRING-LOK RETAINER:

9. RETAIN-B	SPRING-LOK BASE PLATE
10. RETAIN-L	SPRING-LOK
11. RETAIN-S	SPRING
12. RETAIN-C	CLEVIS WITH COTTER
13. RETAIN-CP	CLEVIS PIN 5/16 X 1 3/4"
14. RETAIN-W	1/4" FLAT WASHER
15. BOLT-ST	3/8 SELF TAPPING BOLT



STANDARD 1" AND 1-1/4"
GALVANIZED BOWS

FOR REPLACEMENT IN *TIMPTE TRAILERS* 96" AND 102" WIDE
ROLLMASTER HOPPER BOWS



FOR REPLACEMENT IN
WILSON TRAILERS

96 & 102 WIDE
ALUMI-MASTER BOW

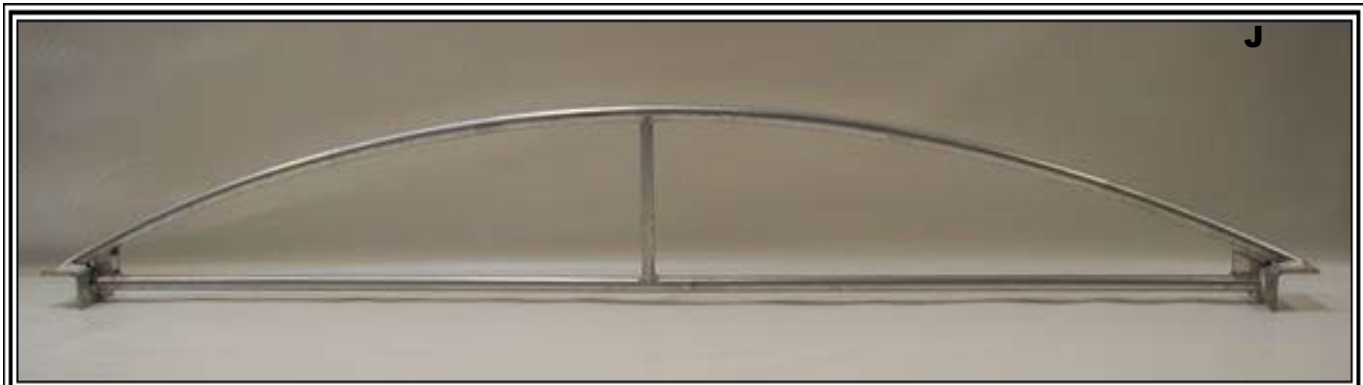

FOR REPLACEMENT IN *CTSTRAILERS* REINFORCED

K





Part #	Pic	Description
BOW12	B	1" COMPLETE GALVANIZED STEEL BOW ASSEMBLY
BOW13	A	1-1/4" COMPLETE GALVANIZED STEEL BOW ASSEMBLY
BOW18		1" GALVANIZED STEEL BOW WITH SHANKS ONLY
BOW19		1-1/4" GALVANIZED STEEL BOW WITH SHANKS ONLY
BOW02	E	1" BOW SHANK ONLY
BOW08	C	1-1/4" BOW SHANK ONLY
BOW03	F	1" STEEL BOW BRACKET ONLY
BOW21	D	1-1/4" STEEL BOW BRACKET ONLY

PICTURE I : FOR REPLACEMENT IN TIMPTE TRAILERS:

BOWHB96R	96" REINFORCED HOPPER BOW
BOWHB96N	96" NON-REINFORCED HOPPER BOW
BOWHB102R	102" REINFORCE HOPPER BOW
BOWHB102N	102" NON-REINFORCED HOPPER BOW

PICTURE J : FOR REPLACEMENT IN WILSON TRAILERS:

BOWAM-96	96" WIDE 10" HIGH RISE ALUMI-MASTER BOW
BOWAM-102	102" WIDE 10" HIGH RISE ALUMI-MASTER BOW

PICTURE K : FOR REPLACEMENT IN CTS TRAILERS

BOW18-CTS	96" WIDE REINFORCED BOW
BOW18-CTS102	102" WIDE REINFORCED BOW

BEST BT TARPS

— SINCE 1987 —



BEST  TARPS

besttarps.com



Built with Revolutionary Double Core

STRENGTH AND FLEXIBILITY

G) BOW-NB

NYLABOW BOW ONLY

H) BOW-NB2

NYLABOW ALUMINUM HOLDER ONLY



NYLABOWS

Designed to withstand temperatures up to 205° and down to -10°. The solid bow inside the outer bow provides a flex and slide that enables strength and flexibility. The outer bow protects the inner bow from absorbing water and provides UV protection so the nylon center does not get hard

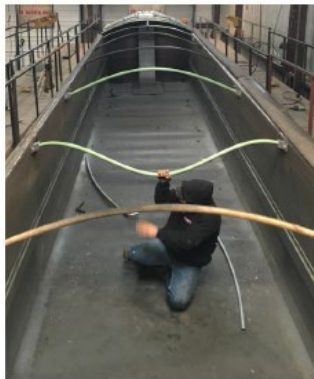

**BEND AND FLEX
BUT DO NOT BREAK!
UV PROTECTED!**

Do not use ridge poles or ridge straps with UnbreakaBOWs

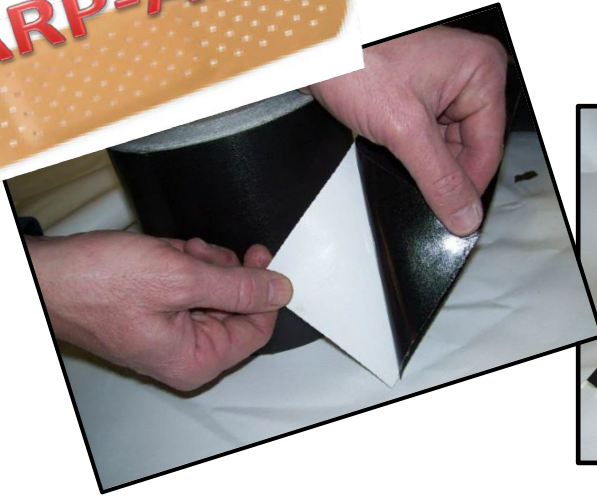

- Part # Patch6-roll 6"x50' roll 18 oz repair tape
- Part # Patch6-case Case of 6 - 6" x 50' rolls
- Part # Patch6-10 6" x 10' roll patch tape

AVAILABLE IN BLACK BLUE RED WHITE GRAY AND GREEN

SPECIFY COLOR WHEN ORDERING

HH-66 GLUE



- GLUE8 HH-66 Vinyl Cement 8 oz Can
- GLUEP HH-66 Vinyl Cement PINT Can
- GLUEQ HH-66 Vinyl Cement QUART Can
- GLUEG HH-66 Vinyl Cement GALLON Can
- GLUET HH-66 Vinyl Glue Cleaner/Thinner
- MAT 18 oz Vinyl Material for patches 12"x10' (specify color)





RIDGE STRAP ASSEMBLIES

1" RIDGE STRAPS

ITEM PART #	DESCRIPTION
1. STRAPA1-46FP	RIDGE STRAP ASSEMBLY 1" X 46' W/FLAT PLATE
2. STRAPA1-46H	RIDGE STRAP ASSEMBLY 1" X 46' W/HOOK
3. STRAP1-46FP	RIDGE STRAP ONLY 1" X 46' W/FLAT PLATE
4. STRAP1-46H	RIDGE STRAP ONLY 1" X 46' W/HOOK
5. STRAPR1-FP	1" RATCHET W/1" WEB STRAP & FLAT PLATE
6. STRAPR1-H	1" RATCHET W/1" WEB STRAP & HOOK

2" RIDGE STRAPS

ITEM PART #	DESCRIPTION
1. STRAPA2-46FP	RIDGE STRAP ASSEMBLY 2" X 46' W/FLAT PLATE
2. STRAPA2-46H	RIDGE STRAP ASSEMBLY 2" X 46' W/HOOK
3. STRAP2-46FP	RIDGE STRAP ONLY 2" X 46' W/FLAT PLATE
4. STRAP2-46H	RIDGE STRAP ONLY 2" X 46' W/HOOK
5. STRAPR2-FP	2" RATCHET W/2" WEB STRAP & FLAT PLATE
6. STRAPR2-H	2" RATCHET W/2" WEB STRAP & HOOK

BEST TARPS

FLAT BED TARPS

FLAT BED TARPS ***FOR: Tarps in stock -Black***

PART NUMBER: COIL6

6' Coil Bag 22 OZ VINYL

PART NUMBER: ST16/16

16' x 16' -18 oz blk
each w/2 rows of d's on all 4 side

PART NUMBER: ST16/27

16' x 27' -18 oz blk
w/2 rows d's all 4 sides

PART NUMBER: ST16/27WF

16' x 27' w/flap -18oz blk
w/2 rows d's per diagram

PART NUMBER: LT6D

6' Drop Tarp-
18 oz top/14 oz sides
20'x27'w/flap
3 rows of d-rings

PART NUMBER: LT8D

8' Drop Tarp
18 oz top/14 oz sides
24'6"x27' w/flap
3 rows of d-rings

PART # LT6D3 6' DROPS -3 PIECE SET

PART # LT8D3 8' DROPS -3 PIECE SET

HIGH QUALITY TRUCK TARPES

LUMBER TARPS

6 foot Drops and 8 foot Drops



6' DROP LUMBER TARPS 18 OZ TOPS 14 OZ SIDES

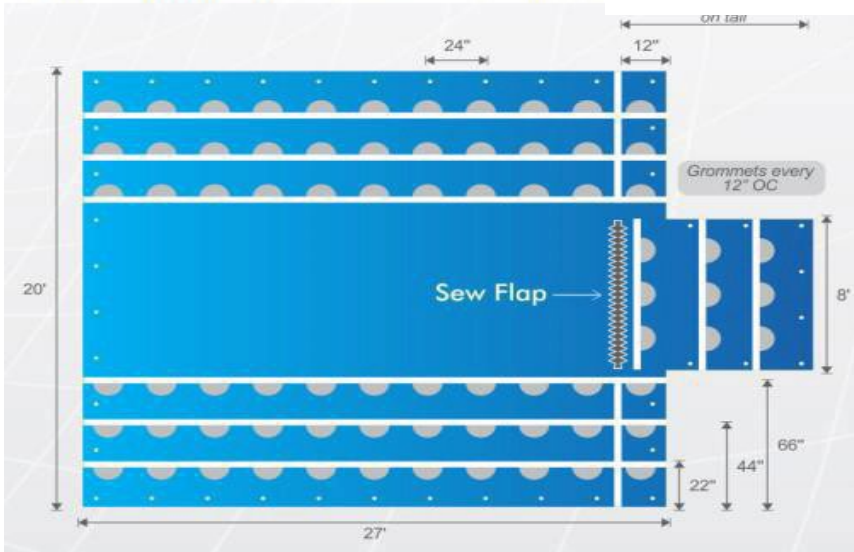

6' DROPS
FINISHED SIZE
20' X 27' PLUS A 6' FLAP
ON ONE END

3 ROWS OF D'S AT
22" 44" 66"
GROMMETTS ON EDGE

18OZ VINYL TOPS

8 foot drop Lumber Tarps 18 oz Top 14 oz sides

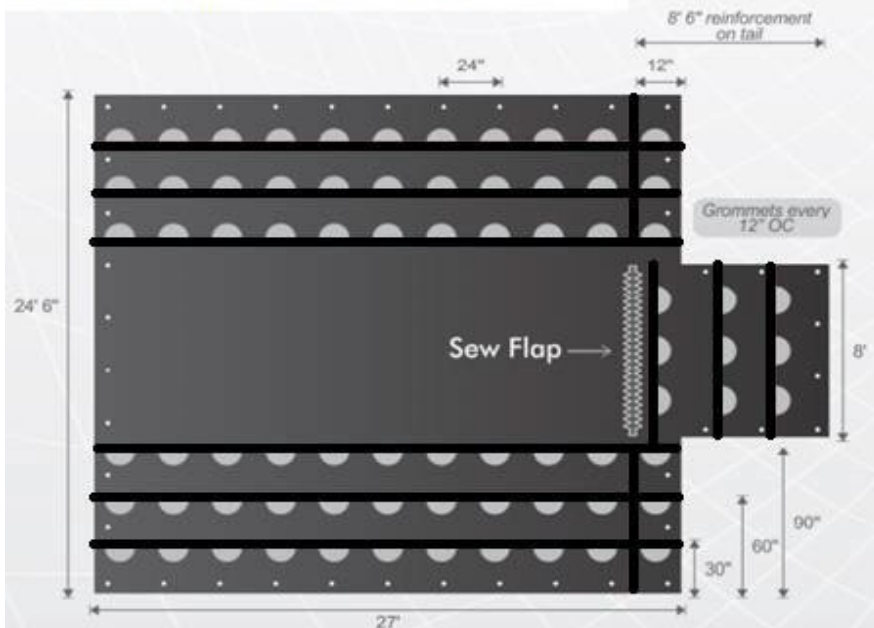

8'DROPS
FINISHED SIZE
24'6" X 27' PLUS A 8'
FLAP
ON ONE END

3 ROWS OF D'S AT
30" 60" 90"
GROMMETTS ON EDGE

18 OZ VINYL TOP

STEEL TARPS

HIGH QUALITY TRUCK TARPS



Steel tarp 18oz.

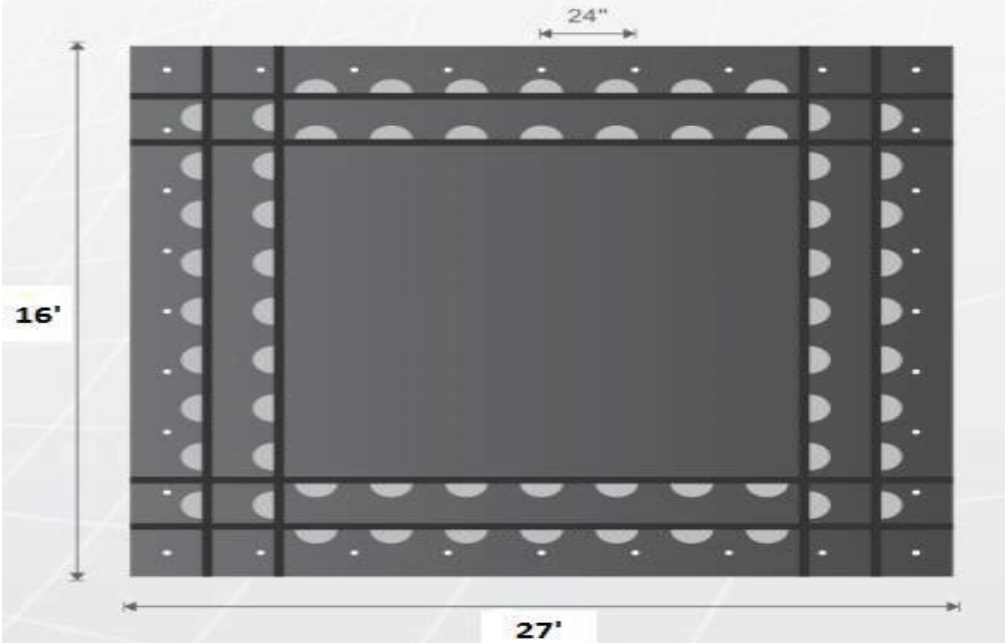

16' X 27'
2 ROWS OF D-RINGS
ALL 4 SIDES
SPACED AT 24" & 48"
GROMETTS ON EDGE
EVERY 24"

4' DROP STEEL/LUMBER TARP WITH FLAP

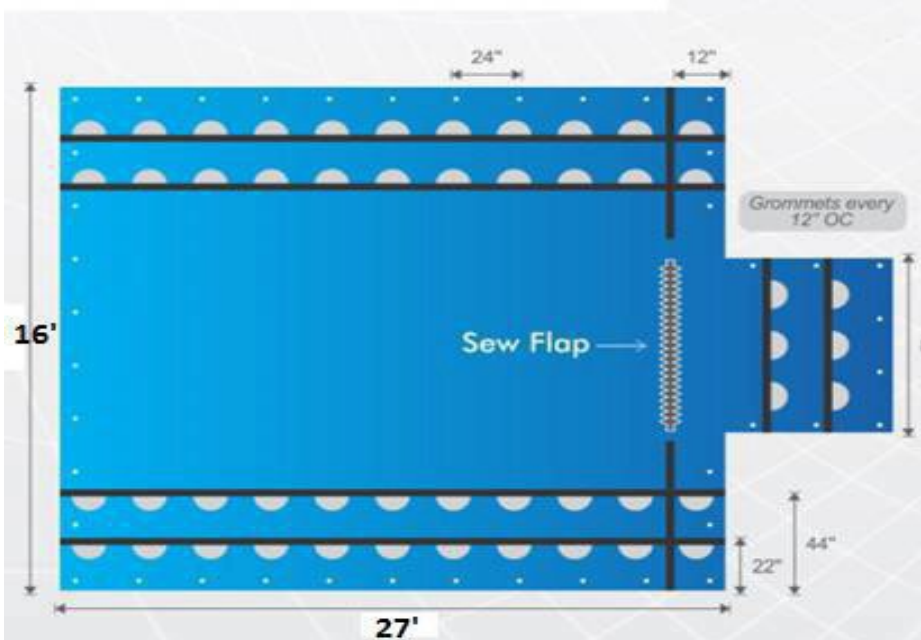

16' X 27' w/4' flap
2 ROWS OF D-RINGS
on 27' sides & flap
SPACED AT 22" & 44"
GROMETTS ON EDGE
EVERY 24"



**COIL BAGS AND
16X16 FLAT STEEL TARPS**



6'6" X 6' X 5'6"
22 OZ VINYL
COIL BAGS

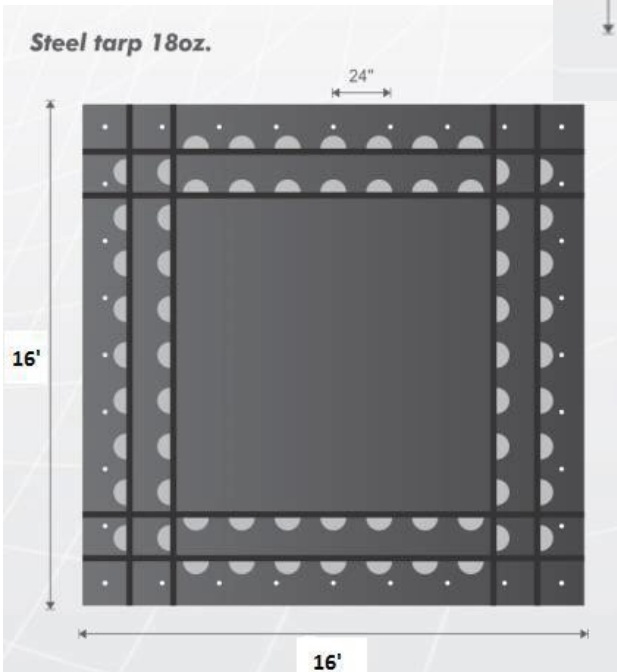
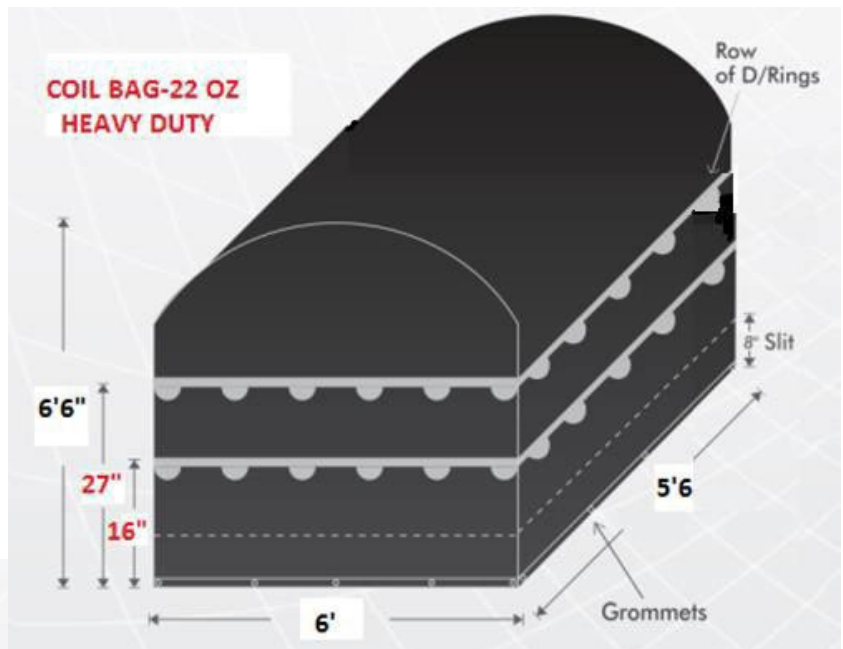

16' X 16'
2 ROWS OF D-RINGS
on all 4 sides

GROMMETTS ON EDGE
EVERY 24"

FRONT TO BACK
SYSTEMS





FRONT TO BACK REPLACEMENT TARPS

BASED ON BED SIZE AND BROKEN DOWN INTO TWO CATEGORIES-MESH OR VINYL

BED SZ	Tarp Sz	MESH PART #	18 OZ Vinyl PART #
10'	12'	FTB01-M10	FTB01-10
12'	14'	FTB01-M12	FTB01-12
14'	16'	FTB01-M14	FTB01-14
15'	17'	FTB01-M15	FTB01-15
16'	18'	FTB01-M16	FTB01-16
17'	19'	FTB01-M17	FTB01-17
18'	20'	FTB01-M18	FTB01-18
20'	22'	FTB01-M20	FTB01-20
22'	24'	FTB01-M22	FTB01-22
24'	26'	FTB01-M24	FTB01-24
26'	28'	FTB01-M26	FTB01-26
28'	30'	FTB01-M28	FTB01-28
30'	32'	FTB01-M30	FTB01-30
32'	34'	FTB01-M32	FTB01-32
34'	36'	FTB01-M34	FTB01-34
36'	38'	FTB01-M36	FTB01-36
38'	40'	FTB01-M38	FTB01-38

FRONT TO BACK ROLL MASTER SYSTEMS

PART #

DESCRIPTION

PRICE

BED SIZE UP TO 22 FOOT:

FTB04 RM Manual Aluminum 4 Spring system
with Wind Deflector

FTB04NWD RM Manual Aluminum 4 Spring system
NO wind deflector

FTB05 RM ELECTRIC Aluminum 4 Spring system
with Wind Deflector

FTB05NDW RM ELECTRIC Aluminum 4 Spring system
NO wind deflector

BED SIZE UP TO 26 FOOT:

FTB06 RM ELECTRIC Aluminum 5 Spring system
with Wind Deflector

FTB06NWD RM ELECTRIC Aluminum 5 Spring system
NO wind Deflector

BED SIZE 28 TO 40 FT:

FTB07 RM Spring Underbody System



TARPS SOLD SEPARATELY ON PREVIOUS PAGE

**DON'T FORGET YOUR TARP MAGS TO PROTECT
YOUR SYSTEM**

4 SPRING MANUAL AND ELECTRIC OPTIONS



5 SPRING ELECTRIC SYSTEM



FTB UNDERBODY SYSTEM



**FRONT TO BACK UNDERBODY SYSTEM FOR BED SIZES 28'-40' AVAILABLE WITH MESH OR VINYL TARP
PART # FTB07 COMPLETE SYSTEM INCLUDED EVERYTHING BUT THE TARP**

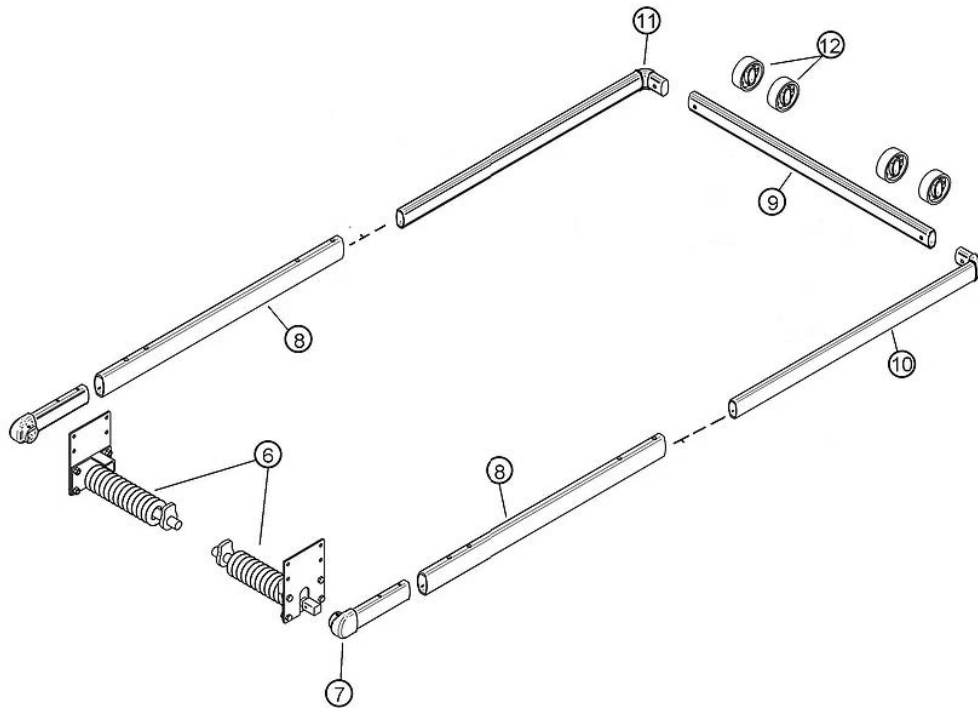

FTB ROLL MASTER PARTS-MANUAL CRANK ASSEMBLY AND PARTS



PART # FTB-CA
MANUAL CRANK ASSEMBLY-STANDARD
W/RETAINER
PART # FTB-CA EXT
MANUAL CRANKASSEMBLY-EXTENDED
W/RETAINER

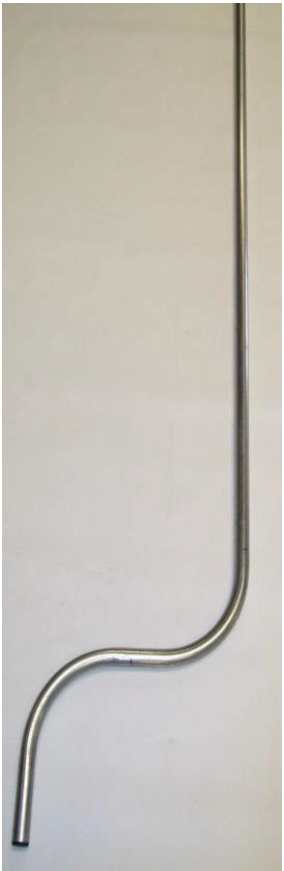

PART # CRANK 05
CRANK ARM
ONLY



PART # UJ03
FTB-U- JOINT



PART # FTB-CRR
CRANK 3/4 ROUND ROD



PART # RETAIN 01
SINGLE CRANK RETAINER



PART # PIN01
SNAPPER PIN



PART # PIN 04
NYLON PIN CABLE

FTB WIND DEFLECTOR & PARTS

PART # FTB-WDP

WIND DEFLECTOR SIDE PLATE

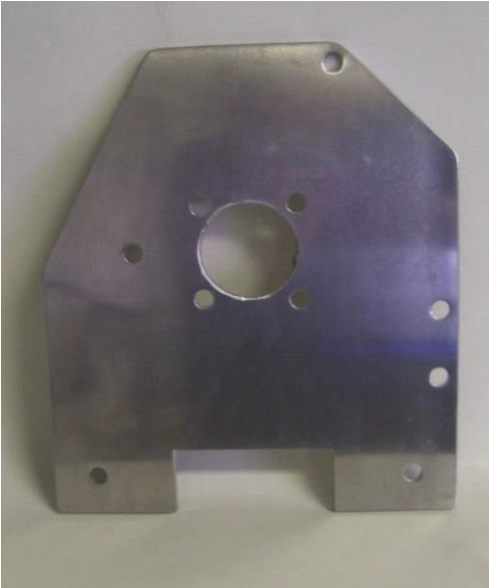

PART # FTB-B

FTB BEARING



PART NUMBER: FTB-WD

WIND DEFLECTOR COMPLETE



FTB ALUMINUM PARTS

PART # FTBAPA-A4

FTB ALUMINUM PIVOT ARM ASSEMBLY 4-SPRING



PART # FTBAPA4

ALUMINUM PIVOT ARM ONLY 4 SPRING



PART # FTBAPA -A5

FTB ALUMINUM PIVOT ARM ASSEMBLY 5-SPRING

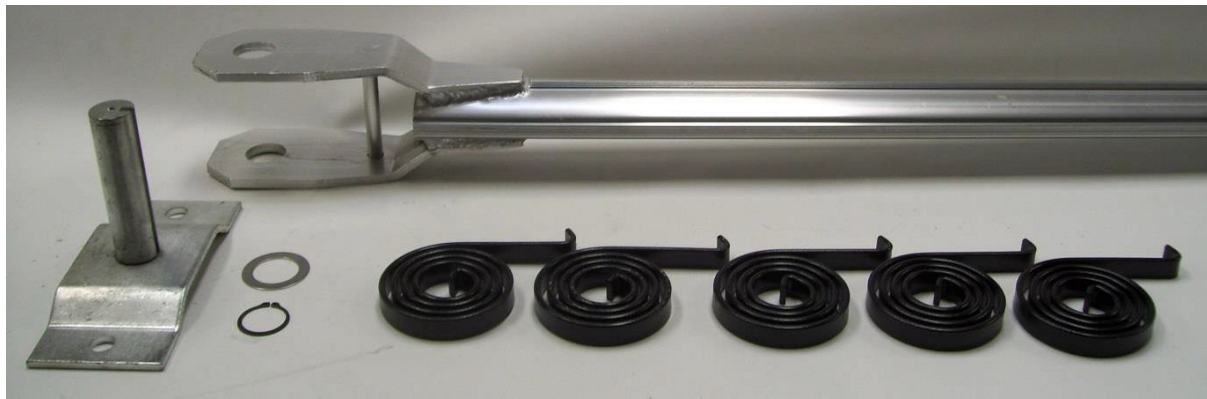

PART # FTBAPA5 FTB ALUMINUM PIVOT ARM ONLY5-SPRING



FTB-SPW

FTB-SMB4

4 SPRING steel MOUNTING BRACKET



FTB-S
TORSION
SPRING

PIVOT MOUNT
WASHER



FTB-SR
SNAP RINGS

FTB-SMB5
5-SPRING

STEEL MOUNTING BRACKET



FTB ALUMINUM PARTS

PART # FTBA90

ALUMINUM 90 DEGREE ELBOW



PART # FTB-APE

ALUMINUM PIVOT ARM EXTENSION



PART # FTB APR

ALUMINUM PIVOT REST

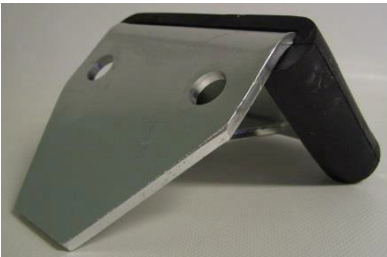

PART # FTPARC-PB
CROSS BAR BUMPERS



PART # FTB-ARC
ALUMINUM REAR CROSS BAR



PART # FTB-ART ROLL TUBE



FTBM-A
50:1 GEAR RATIO
STANDARD MOTOR
FOR BEDS UP TO 22



PART # FTB ESK1 SWITCH KIT



PART # FTB-MHD
HEAVY DUTY MOTOR
FOR BEDS OVER 20 FT



FTBW6 6G WIRE



FTB-EB 50 AMP BREAKER



FTBW14 14G WIRE



FTB-ES01
ROCKER SWITCH

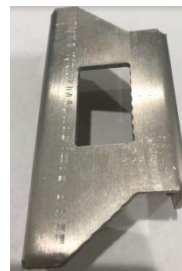

FTBESK-C
SWITCH CASE



FTB-ES02
ROCKER SWITCH

PART # FTBETPS COMPLET ELECTRIC TRAILER PLUG SET

PIC A) FTB-TPF FEMALE END PLUG ONLY

PIC B) FTB-TPM MALE END PLUG ONLY



**FTB-PT
25 FOOT POWER CORD/PIG TAIL**



**FTBES
ELECTRIC SOLENOID**

Part number: FTBECP Complete connector package (qtys pictured)

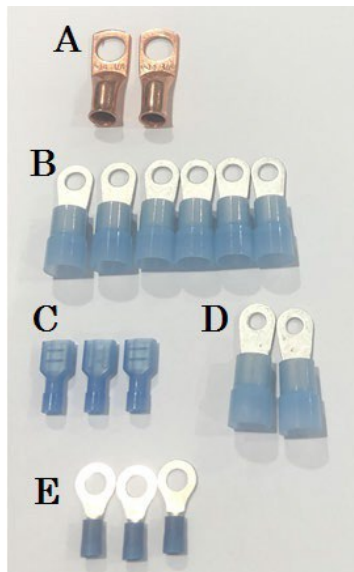

A) FTBEC2 Copper connectors

B) FTBEC1 1/4" Nylon ring terminal

C) FTBEC5 Female Nylon push on terminal

D) FTBEC4 Nylon ring terminal 10 stud

E) FTBEC3 Vinyl ring terminal 1/4" Stud

FTB UNDERBODY SYSTEM PARTS

FTB-UBPC PIVOT CAST FOR UNDERBODY SYSTEM



FTB-UBB

Under Body Bearing



FTB-UBSA-D

**FRONT TO BACK UNDERBODY
SPRING ASSEMBLY -DRIVER SIDE**

FTB-UBSA-P

**FRONT TO BACK UNDERBODY
SPRING ASSEMBLY-PASSENGER SIDE**



FTB-UBSO-D

FRONT TO BACK SPRING ONLY-DRIVER

FTB-UBSO-P

FRONT TO BACK SPRING ONLY-PASSENGER

FTBAP12 AND FTBAP16

**FTB ALUMINUM PIVOT ARM
FOR UNDERBODY SYSTEM**

PART #

FTBAP12 12'ARM

FTBAP16 16'ARM





NEW PATENTED ELECTROMAGNETIC LOCKING DEVICE FOR FRONT TO BACK TARP SYSTEMS, **THE TARP MAG™** USES TWO 300 LB ELECTRO MAGNETS TO HOLD DOWN ALUMINUM OR STEEL ARMS TO PREVENT COSTLY DAMAGE TO FRONT TO BACK SYSTEMS. USING STEEL CONTACT PLATES ATTACHED TO EXTENSION ARMS AND A MULTI FUNCTIONAL ROCKER SWITCH, WHEN THE TARP IS IN THE CLOSED POSITION, THE ELECTROMAGNETS USE 300 LBS OF PRESSURE PER SIDE TO KEEP THE ARMS SECURELY LOCKED IN PLACE. WHILE TRAVELING DOWN THE ROAD OR IN WINDY CONDITIONS, THE TARP MAG SYSTEM PREVENTS VERY COMMON AND EXPENSIVE DAMAGE TO THE ARM SETUP ON FRONT TO BACK TARP SYSTEMS AND CAN BE RETRO FITTED TO MOST SYTEMS ON THE MARKET. WITH THE 4 PRONG PLUG SET AND MULTI FUNCTIONAL SWITCH, EVERYTHING WORKS SEAMLESSLY WITH THE TARP SYSTEM, ELIMINATING ADDITIONAL STEPS TO OPERATE. **THIS PATENTED TECHNOLOGY IT TRULY MAG-NIFICENT!**

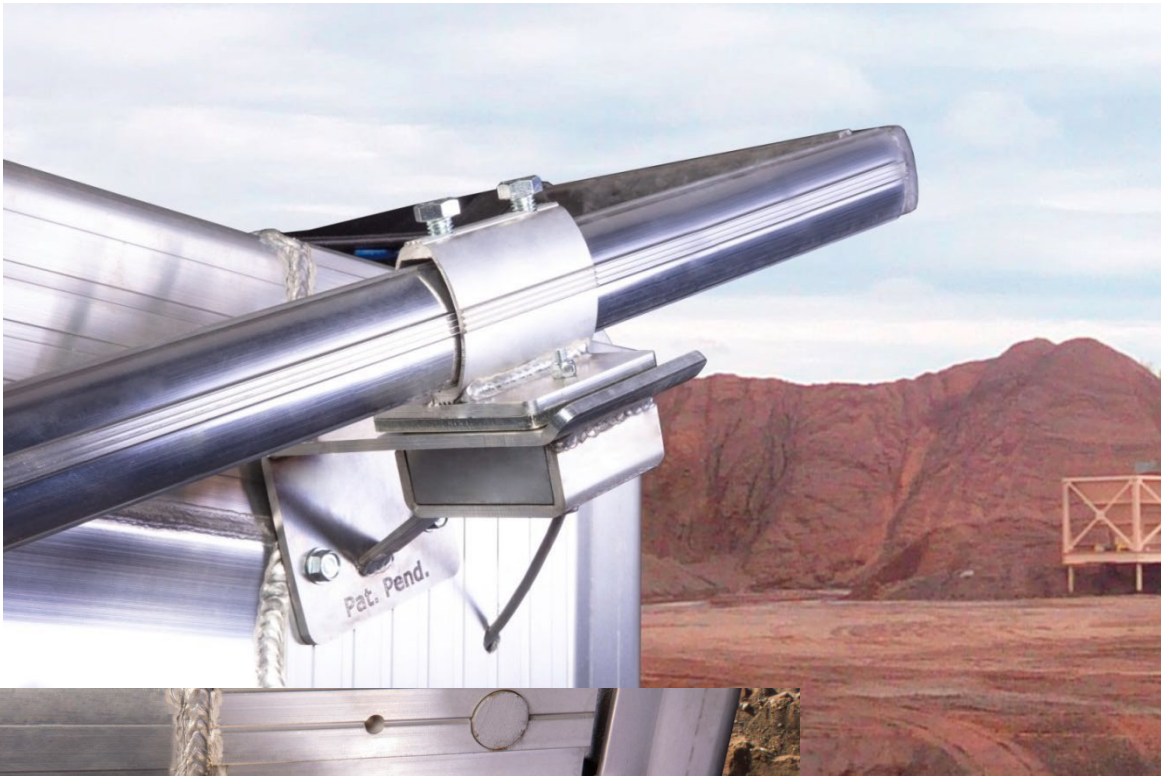

COMPLETE TARP MAG™ SYSTEM

Part # TARPMAG

System includes 14g dual strand switch wire, solenoid, 50 amp breaker, 4 prong male & female trailer plug, multi function rocker switch kit with kill switch that operates both the tarp system and the Tarp Mag™, two extension arm contact plate assemblies, and to 300 lb electromagnetic Tarp Mag assemblies.



- A. # **TM-O** Tarp Mag Only
- B. # **TM-B** Tarp Mag Bracket
- C. # **TM-A** Tarp Mag Bracket Assembly
- D. # **TM-CP** Contact Plate Assembly
- E. # **TM-S** Multi function Switch Only
- F. # **TM-SK** Tarp Mag Complete Switch Kit
- G. # **TM-TPS** 4 PRONG Trailer Plug Set
- H. # **TM-W** 14 Gauge dual strand wire
- I. # **FTB-ES** Solenoid
- J. # **FTB-EB** 50 AMP BREAKER

